

MSD INSTALLATION INSTRUCTIONS

MSD 7AL-3, Ignition Control PN 7330

ONLINE PRODUCT REGISTRATION: Register your MSD product online. Registering your product will help if there is ever a warranty issue with your product and helps the MSD R&D team create new products that you ask for! Go to www.msperformance.com/registration.

Important: Read the instructions before attempting the installation.

Parts Included:

- 1 - 7AL-3, PN 7330
- 1 - Parts Bag (wires and connectors)
- 4 - RPM Modules 3000, 7000, 8000, 9000
- 4 - Retard Modules 2°, 3°, 4°, 5°, 10°, 15° and 20°
- 4 - Zero Degree Modules
- 4 - Vibration Mounts

WARNING: During installation, disconnect the battery cables. When disconnecting the battery, always remove the Negative cable first and install it last.

Note: The MSD 7AL-3 will retard the ignition timing approximately 4° compared to other MSD Ignitions. After installation, the timing should always be checked and adjusted at idle and total timing.

COIL RECOMMENDATIONS

The MSD 7AL-3 can be used with a variety of coils, but to receive the best performance, it is recommended to use an MSD Coil. For drag racing and “short duration” applications, the Pro Power Coil, PN 8201. For street applications or long duration racing events, the HVC Pro Power Coil, PN 8251 or PN 8261 are recommended. The 7AL-3 may be used with a GM HEI Distributor with an internal coil, however the Rotor Bushing **must** be replaced with an MSD Low Resistance Bushing, PN 8412.

MOUNTING

The 7AL-3 can be mounted under the hood, but should be mounted in a position away from direct engine heat sources. Use the ignition as a template and mark the location of the mounting holes. Remove the unit and drill the holes using a 1/4" bit. Install the vibration mounts to the 7AL-3 then mount the ignition using the supplied lock washers and nuts.

CYLINDER SELECT

This ignition can be used on 4, 6 (even-fire) or 8-cylinder engines. The ignition is set for 8-cylinder operation. To program the unit for other engines, remove the one screw that holds the cover to reveal two wire loops (Figure 1). Cutting a wire loop determines the cylinder selection.

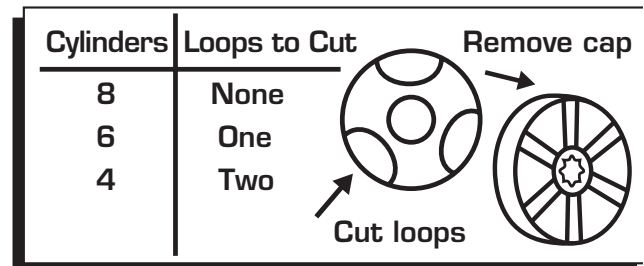

Figure 1 Cylinder Programming.

WIRING

Wiring the 7AL-3 will be simple by following the instructions. There are several color coded wires supplied with the 7AL-3 and should be used as noted to avoid confusion or wrong connections. This section is also broken down into two sections; Primary Wiring and Optional Wiring.

- The Primary section designates the wires that must be connected to run the engine.
- The Optional Wiring section explains the wiring of optional built-in features such as the Rev Controls, RPM Activated Switch and Retard Controls. This information starts on page 6.

WARNING: The 7AL-3 produces very high voltages. Never short the battery or coil terminals. Use caution during installation and while working near the ignition.

PRIMARY WIRING

1. Begin wiring the MSD by connecting the wires responsible to run the engine. The terminal strip on the left side of the box is responsible for the Power Leads and the Coil Wires. Connect the supplied wires as follows:

Heavy Red: Connect from the “Batt +” terminal directly to the battery positive (+) terminal.

Heavy Black: Connect from the “Batt -” terminal directly to the battery negative (-) terminal.

Orange: Connect from the “Coil +” terminal to the positive terminal (+) of the coil (570V).

Black: Connect from the “Coil -” terminal to the negative terminal (-) of the coil (Ground).

2. Move to the middle terminal strip and locate the terminal marked “Ignition”. Use the supplied RED wire and connect it to a switched 12 volt source (ignition switch).
3. If a retard function is not going to be used the supplied "zero" degree module must be installed. See the Multi-Step Retard Section.
4. The three terminals on the bottom of the middle terminal strip receive the trigger signal from the distributor. One terminal is for points style applications and the other two are for use with a magnetic pickup trigger, such as an MSD Billet Distributor or Crank Trigger.

Note: The Points and Mag Pickup terminals will never be connected at the same time.

Points: If you are using a Points style distributor or electronic amplifier, only the “Points” terminal will be used. Connect the supplied WHITE wire from the points output in the distributor to the “Pnts” terminal (Figure 1).

Magnetic Pickup: If you are using an MSD Distributor or Crank Trigger, only the Magnetic Pickup terminals will be used. Locate the supplied harness with a VIOLET and GREEN wire with a 2-pin connector on one end. Connect the VIOLET wire to the “Mag +” terminal and the GREEN wire to the “Mag -” terminal then connect the 2-pin connector to the Distributor (Figure 1).

Magnetic Pickup Polarity

The MSD 7AL-3 can be used with other magnetic pick-up distributors as long as the wires are connected correctly. The chart on the right shows the polarity of some common magnetic pickups.

Common Mag Pickup Wires		
Distributor	Colors	
	Mag+	Mag-
MSD	Org/Blk	Vio/Blk
MSD Crank Trigger	Violet	Green
Ford	Orange	Purple
Accel ^{46/48000} Series	Org/Blk	Vio/Blk
Accel ^{51/61000} Series	Red	Black
Chrysler	Org/Wht	Black
Mallory	Org/Blk	Vio/Blk

Figure 1

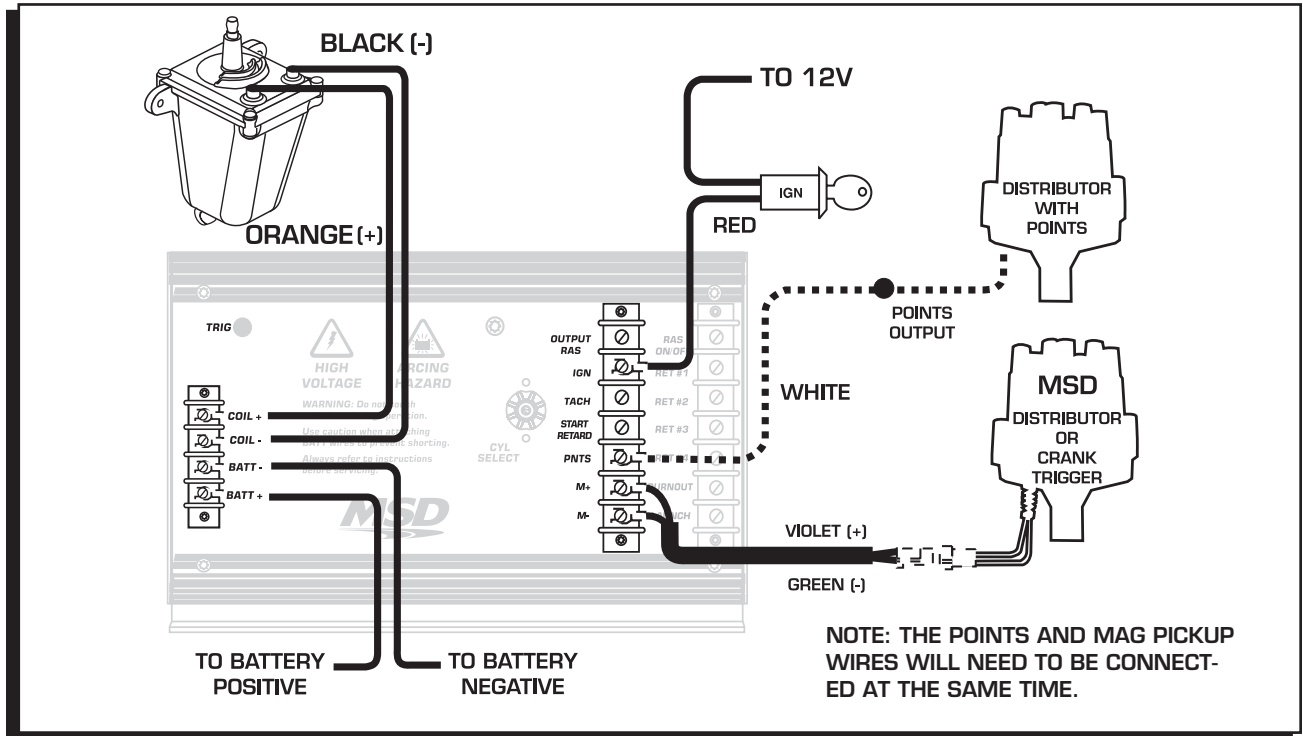

Figure 2 Wiring the Primary Side of the Ignition to Points or Magnetic Pickup.

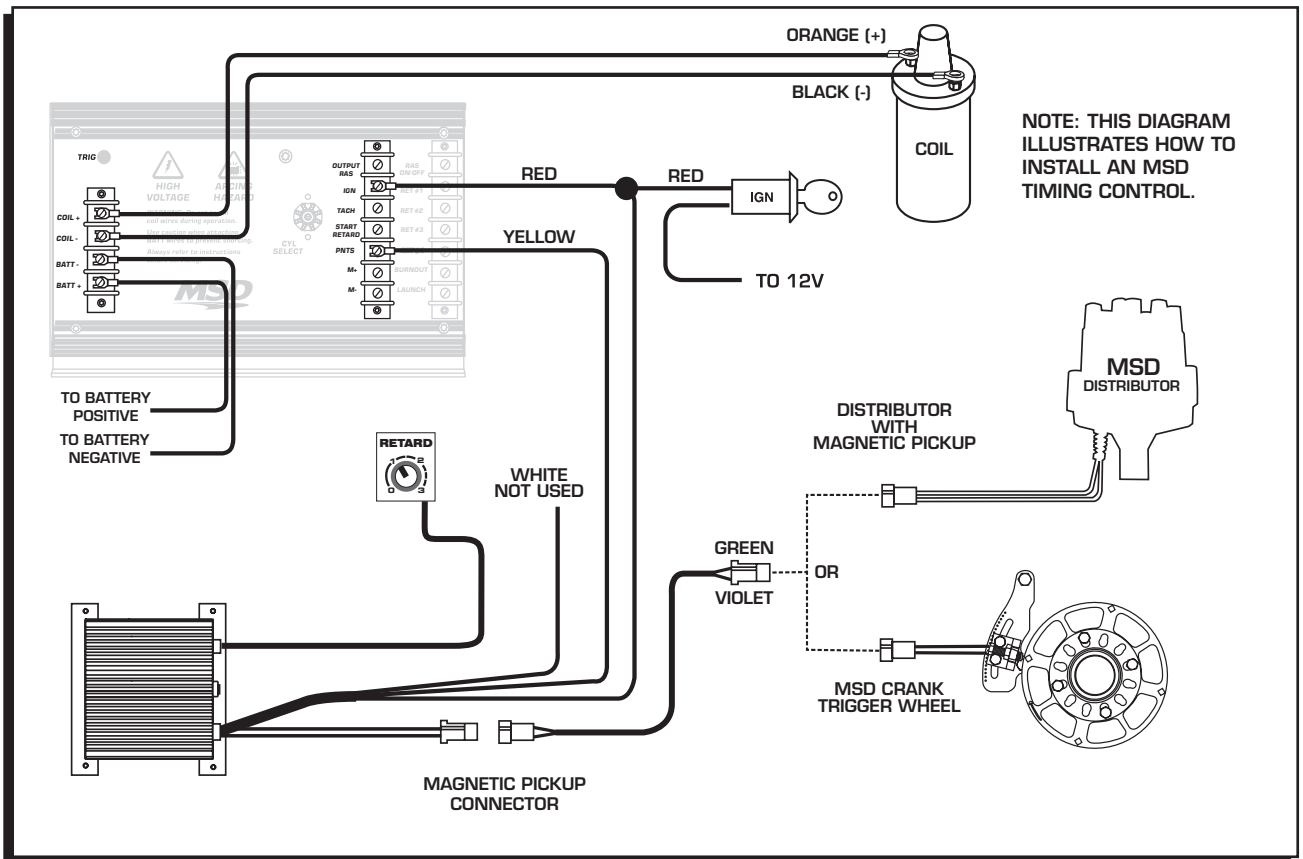

Figure 3 Primary Wiring to an MSD Timing or Boost Control and a Magnetic Pickup.

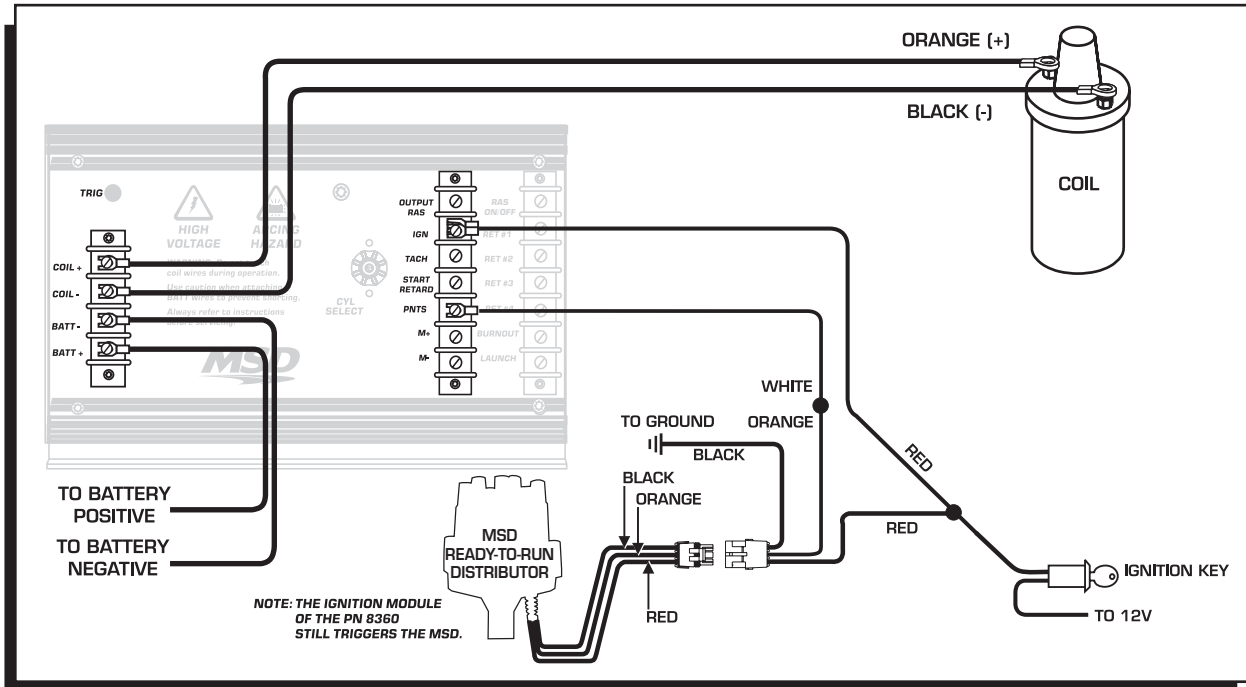

Figure 4 Primary Wiring to an MSD Ready-to-Run Distributor.

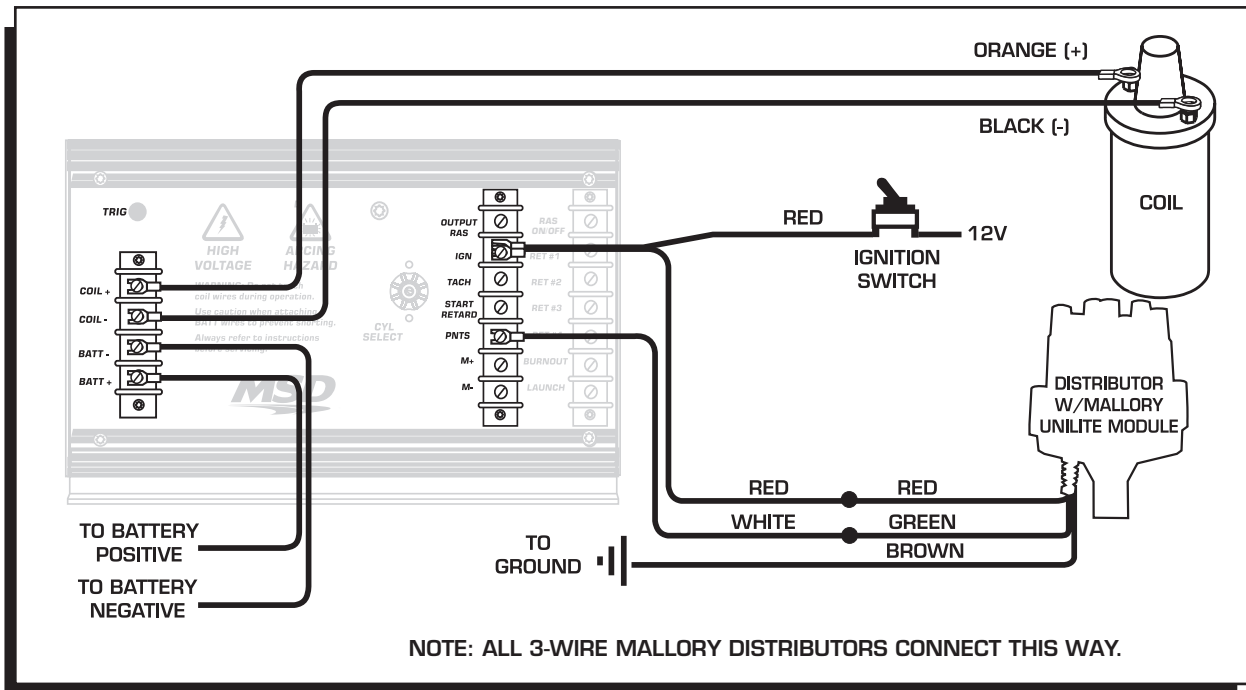

Figure 5 Primary Wiring to a Mallory Unilite Distributor.

Note: The MSD 7AL-3 will retard the ignition timing approximately 4° compared to other MSD Ignitions. After installation, the timing should always be checked and adjusted at idle and total timing.

OPTIONAL WIRING

This Wiring Section details the optional features of the MSD 7AL-3 and how to wire each system.

START RETARD

The Start Retard of the 7AL-3 is designed to ease cranking on engines with locked timing, high compression and a lot of advance. The amount of retard is determined by a plug-in degree module (Figure 8). There are two different ways to activate this function (Figure 9):

A. Switched 12 Volts

In this set up, the timing is retarded only while the engine is cranking. Connect the supplied Violet wire from the "Start-Retard" terminal on the 7AL-3 to the starter solenoid. This way, 12 volts is only applied when the key or switch is in the cranking position. When the switch is released, 12 volts is removed and the timing returns to run timing.

B. Constant 12 Volts

In this setup, whenever the ignition is turned On, 12 volts is applied and the retard function is activated. The retard will be removed when the engine reaches about 600 rpm and will not occur again until the ignition is turned **Off**. Connect the supplied jumper from the Start-Retard terminal to the IGN terminal of the terminal strip (two terminals up).

THREE STEP RPM LIMITS

The 7AL-3 has a built-in Three Step Module Selector which allows you to select up to three different rpm limits. The activation terminals are located on the bottom of the third terminal strip and are listed as Launch and Burnout. The third rpm limit is the high rpm, which is always active when there is an rpm module installed in the "Race" holder (except when the other rpm limits are activated).

These modules can be used in a variety of functions and are not limited to launches and burnouts. Each of the two optional rpm limits are activated when 12 volts is applied to their corresponding terminals (Figure 10). The 12 volts can come from switches, solenoids or relays giving you a variety of ways to activate the different rpm limits. The following steps illustrate a general drag race installation for use with a Burnout limit, Launch limit and Race limit.

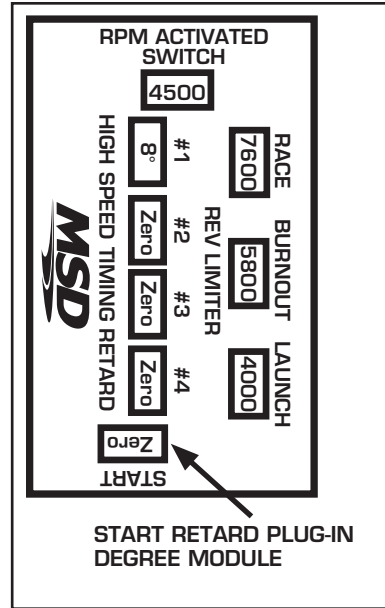

Figure 8 Side View of 7 AL-3

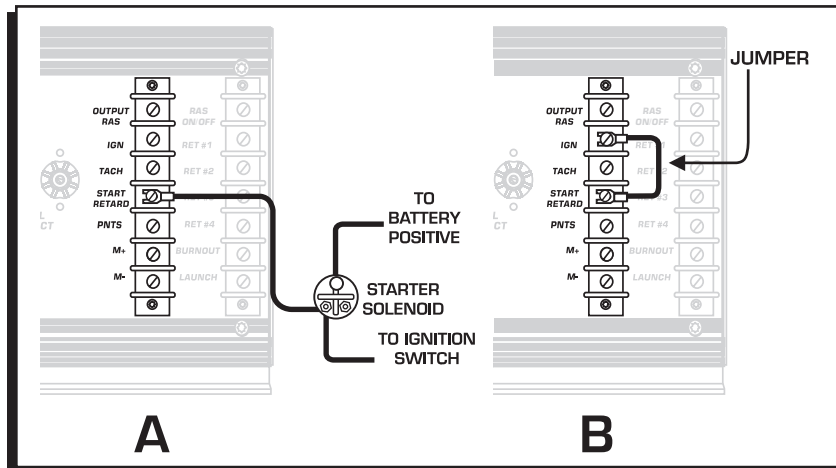

Figure 9 Wiring the Start Retard Function.

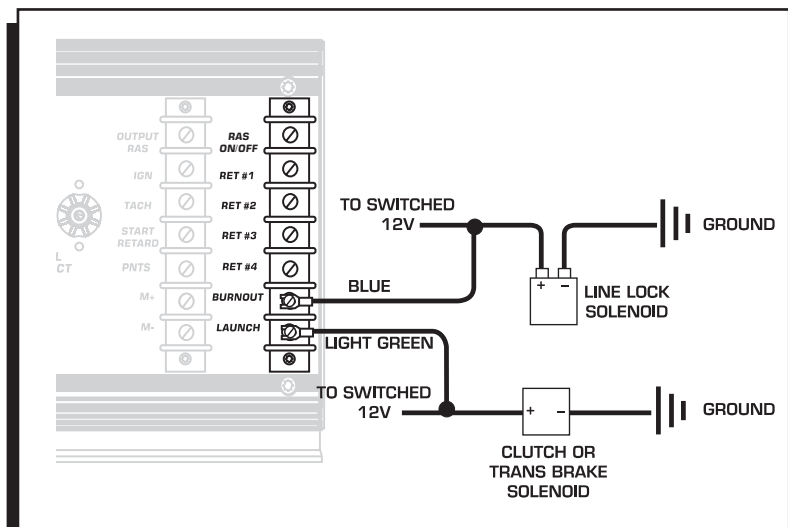

Figure 10 Connecting the Three Step Module Selector.

Burnout Rev Limit:

Connect the supplied Blue wire from the Burnout terminal of the MSD to the 12 volt activation wire of the line lock solenoid. With this setup, when the line lock is activated, 12 volts will be supplied to the Burnout terminal which limits the rpm to your specified burnout rpm module.

Launch Rev Limit:

Connect the supplied Light Green wire to the Launch terminal of the MSD then splice it into the clutch or trans brake 12 volt activation wire. This way, when the clutch pedal is depressed, 12 volts is applied to the Launch terminal which limits the rpm to your specified launch rpm module.

Note: The Launch rpm limit is designed to override the Burnout limit. This way, if you activate the line-lock on the starting line, when the Launch terminal is activated through the trans brake or clutch switch, the Launch rpm (not the Burnout limit) will be in effect. After the car launches the Race rpm limit is activated to protect the engine from over revving.

RPM ACTIVATED SWITCH

The RPM Activated Switch (RAS) Output will turn on a component such as a shift light or nitrous solenoid at an adjustable rpm point by supplying a ground path (Figure 11). The RPM Switch is capable of handling a 10 amp load. If 12 volts is required to activate the component, use an MSD Relay, PN 8960 or PN 8961.

The 7AL-3 also features an "RAS On/Off" for the RPM Activated Switch. To use the RPM Switch, 12 volts **must** be connected to the "RAS-On/Off" terminal located at the top of the third terminal strip. Whenever the 12 volts is removed from this terminal, the RPM Activated Switch **will not** operate. This is a useful feature for only turning on a nitrous solenoid in high gear

by incorporating a switch on the shifter (Figure 12).

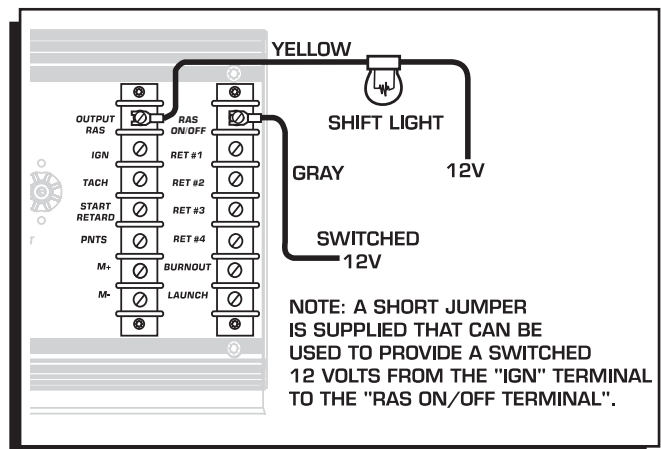

Figure 11 Connecting the RPM Activated Switch.

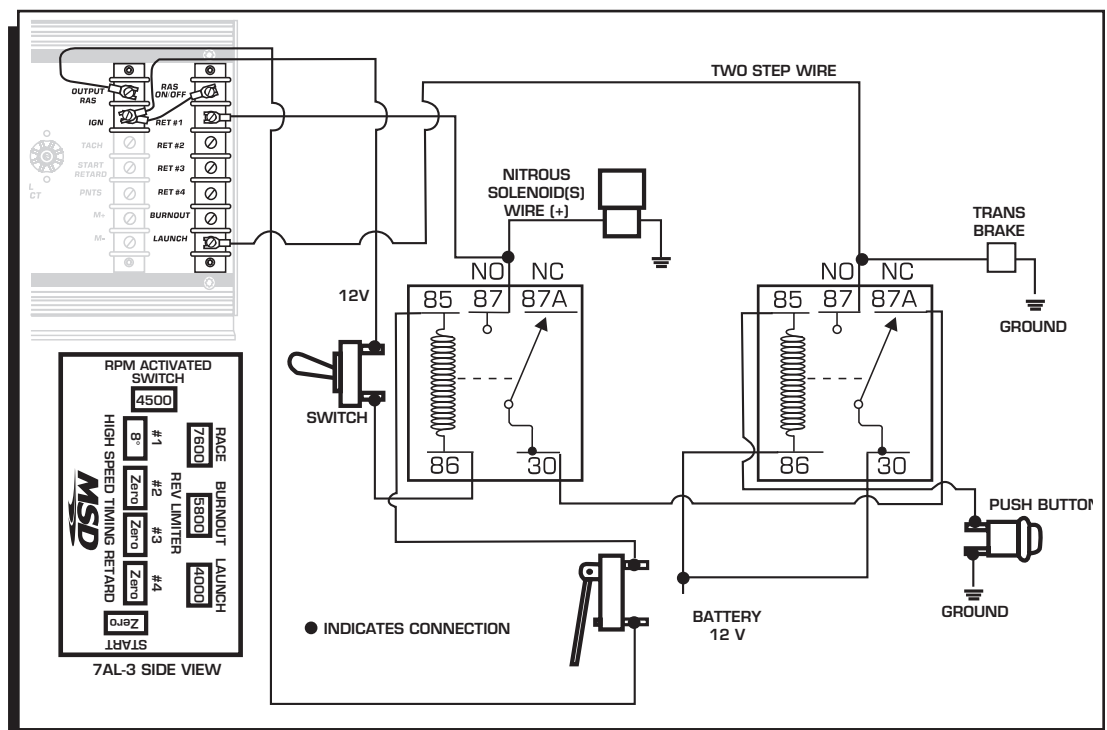

Figure 12 Turning on Nitrous with R.A.S. after Transbrake is released.

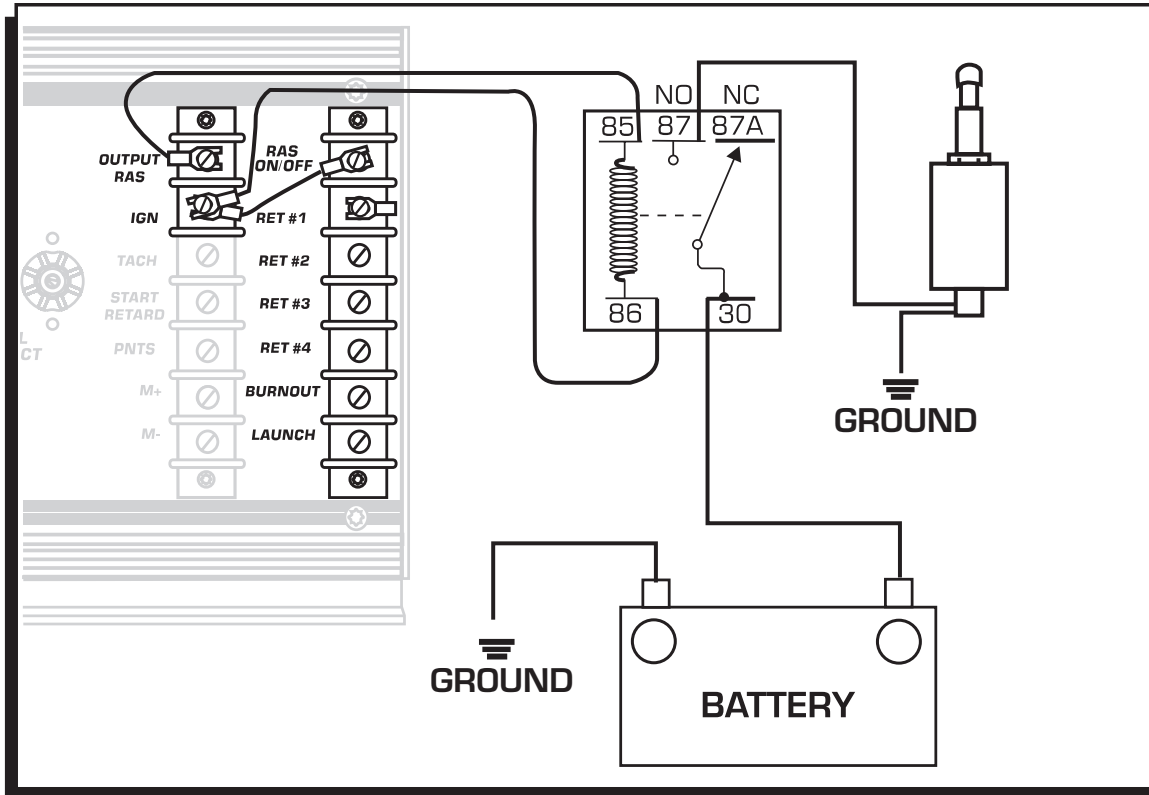

Figure 13 Wiring the RAS to activate a Plunger Style Shifter (12V input).

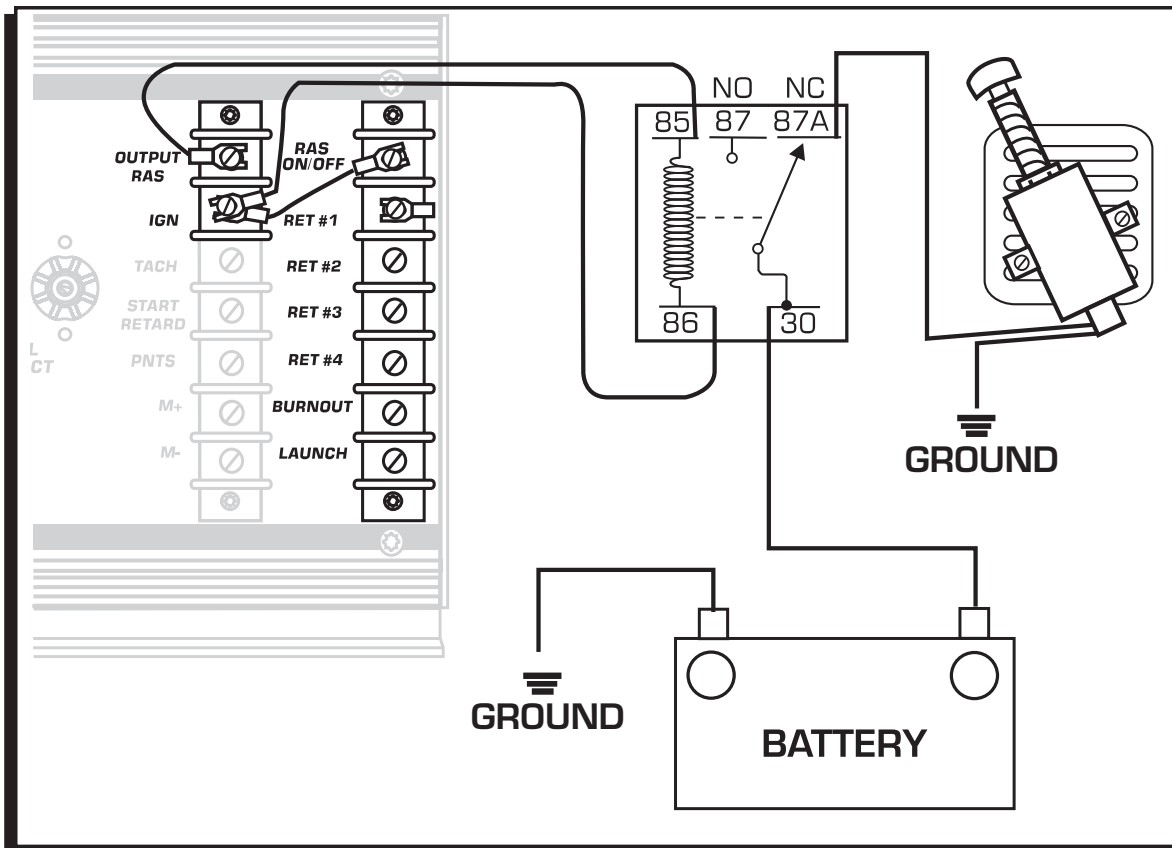

Figure 14 Using the RAS to Activate a Shift Solenoid (takes away 12V power).

MULTI-STEP RETARD

There are four retard modules available with the 7AL-3. Each module is activated independently by supplying 12 volts on the terminal from the corresponding module. The controlling terminals are listed as RET-1 through RET-4 and are located on the third terminal strip. The modules can be activated in any order and are cumulative unless deactivated. The maximum amount of retard allowed is a total of 20° even if the modules add up to more than 20°.

Note: If a Retard function is not going to be used it is recommended to install a "zero" degree module. See page 12 for more module part numbers.

RETARD WITH THE RPM ACTIVATED SWITCH

The MSD 7AL-3 has both an RPM Activated Switch (RAS) and a Multi-Step Retard. The stages of retard are activated when the corresponding activation wire is disconnected to 12 volts. The RAS can only activate a circuit by *providing a ground path*.

If you want to use the RAS to activate a retard stage of the 7AL-3, an external relay must be used. The MSD Relay, PN 8961, is supplied in the parts bag with the 7AL-3. Figure 14 shows how to connect the relay for this application.

Note: Make sure 12 volts is applied to the RAS On/Off terminal.

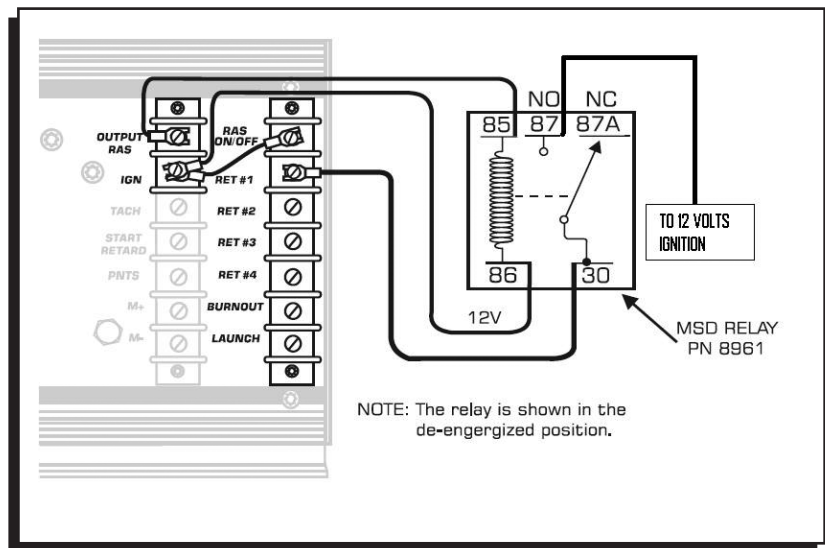

Figure 15 Activating the RAS in High Gear Only.

For more custom drawings, go to www.msperformance.com.

TACHOMETER

This terminal provides a square wave 12 volt, 20% duty cycle signal for your tachometer. Use the supplied Brown wire and connect it to the Tach terminal strip (Figure 16). If your tachometer reads erratic or does not operate properly, a Tach Adaptor may be required. If you are using the white wire to trigger (points input) you will need Adapter PN 8910. If you are using the magnetic pickup, PN 8920 will be the right Adapter. Contact your MSD dealer.

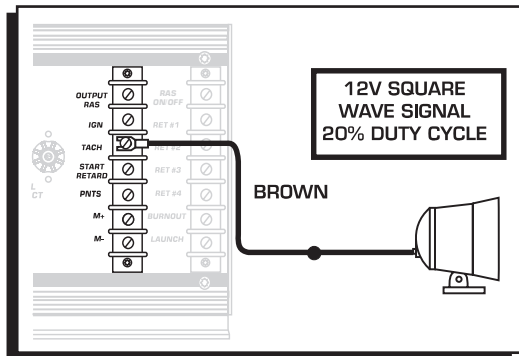

Figure 16 Connecting a Tachometer.

KILL SWITCH

If your racing application requires an ignition kill switch it is easy to incorporate into the ignition's trigger input wire. When the trigger input terminal is grounded, the ignition is killed. A Single-Pole, Single Throw Switch is required (MSD PN 8806).

Points: Connect one side of the switch to ground and the other side to the Points terminal of 7AL-3 (Figure 17).

Mag Pickup: Connect one side of the switch to ground and the other side to the Mag+ terminal of 7AL-3 (Figure 18).

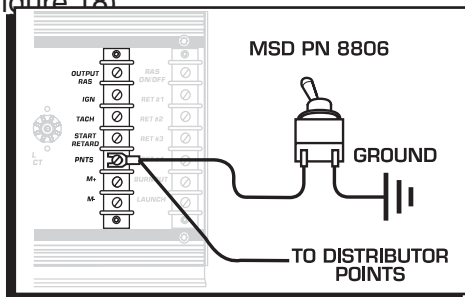

Figure 17 Connecting a Kill Switch to Points.

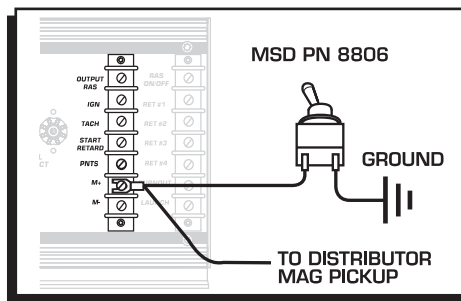

Figure 18 Connecting the Kill Switch to the Mag+.

TROUBLESHOOTING

If for some reason you suspect that the ignition system is not functioning properly, follow the proceeding procedures to determine if the MSD is functioning properly.

TRIGGER LED

The MSD 7AL-3 is equipped with a Green LED..

Green: The Green LED indicates that the ignition is receiving a trigger signal. If it is not operating, the trigger mechanism, either crank trigger or distributor, is not delivering a trigger signal. If the engine will not run though the Green LED shows a trigger signal, follow the "Checking for Spark" procedure on page 11.

MSD offers an Ignition Tester, PN 8998, that will check the Ignition and Coil's operation. (The obsoleted Tester PN 8995, can only be used on the points input.)

WIRING CHECK

WARNING: The 7AL-3 produces very high voltages. Never short the battery or coil terminals. Use caution during installation and while working near the ignition.

- Check all of the wire connections making sure they are clean and tight. If connectors have been crimped on make sure they are tight and sealed.
- Make sure the battery is fully charged and properly connected. Also confirm that the MSD power leads are connected properly and are tight.
- With a test light check that there is voltage on the RED "Ignition" terminal of the MSD when the ignition is in both the On and START position.
- Check that the only wires connected to the coil are from the MSD. ORANGE should connect to the positive terminal (570V), BLACK to the negative terminal (Ground).

Note: DO NOT connect any test equipment to the coil terminals.

After checking the wiring for loose or faulty connections, follow the next steps to confirm that the unit is "sparking" properly.

CHECKING FOR SPARK

The following procedures will determine if the ignition is producing a spark. Before proceeding, inspect all of the wiring and ensure that the Green LED is flashing when the engine is cranked. This ensures that the ignition is receiving a trigger signal .

Magnetic Pickup (Green and Violet):

1. Make sure the ignition is turned OFF and remove the coil wire from the distributor cap. Pull the boot back so the terminal is easy to see and position the wire 1/2" from ground.
2. Disconnect the magnetic pickup connector from the distributor.
3. Turn the ignition switch to the ON position. DO NOT CRANK THE ENGINE.
4. Take a small length of wire and short the Green and Violet wires together 3 or 4 times. A spark should jump from the coil wire to ground every time the connection is broken.
5. If there is no spark, substitute another coil and test again. If there is still no spark and all of the wiring connections have been confirmed, contact the MSD Customer Service Line and send the unit in for repair.

White Wire Trigger:

1. Make sure the ignition is turned OFF and remove the coil wire from the distributor cap. Pull the boot back so the terminal is easy to see and position the wire 1/2" from ground.
2. Disconnect the White wire from the distributor.
3. Turn the ignition switch to the ON position. DO NOT CRANK THE ENGINE.
4. Tap the White wire to ground 3 or 4 times. A spark should jump from the coil wire to ground when the white wire is removed from ground.
5. If there is no spark, substitute another coil and test again. If there is still no spark and all of the wiring connections have been confirmed, contact the MSD Customer Service Line and send the unit in for repair.

INSTALLATION INSTRUCTIONS

RETARD MODULE SELECTORS

The Retard Module Selector allows you to select between 12 retard amounts with the turn of a dial. The Selectors plug into the retard module receptacle of any MSD Timing Control.

Retard Module Selector, 0° - 11°, PN 8676

Retard Module Selector, 0°/10°-20°, PN 8678

RETARD MODULES

MSD Retard Module Kits give you a full selection of retard modules to be used with any timing controls.

11°, 12°, 13°, 14°, 15° - PN 8774

16°, 17°, 18°, 19°, 20° - PN 8775

5°, 6°, 7°, 8°, 9°, 10° - PN 8776

1°, 2°, 3°, 4°, 5° - PN 8777

Service

In case of malfunction, this MSD component will be repaired free of charge according to the terms of the warranty. When returning MSD components for warranty service, **Proof of Purchase** must be supplied for verification. After the warranty period has expired, repair service is based on a minimum and maximum fee.

All returns must have a Return Material Authorization (RMA) number issued to them before being returned. To obtain an RMA number please contact MSD Customer Service at 1 (888) MSD-7859 or visit our website at www.msdpower.com/rma to automatically obtain a number and shipping information.

When returning the unit for repair, leave all wires at the length in which you have them installed. Be sure to include a detailed account of any problems experienced, and what components and accessories are installed on the vehicle. The repaired unit will be returned as soon as possible using Ground shipping methods (ground shipping is covered by warranty). For more information, call MSD at (915) 855-7123. MSD technicians are available from 7:00 a.m. to 5:00 p.m. Monday - Friday (mountain time).

Limited Warranty

MSD warrants this product to be free from defects in material and workmanship under its intended normal use*, when properly installed and purchased from an authorized MSD dealer, for a period of one year from the date of the original purchase. This warranty is void for any products purchased through auction websites. If found to be defective as mentioned above, it will be repaired or replaced at the option of MSD. Any item that is covered under this warranty will be returned free of charge using Ground shipping methods.

This shall constitute the sole remedy of the purchaser and the sole liability of MSD. To the extent permitted by law, the foregoing is exclusive and in lieu of all other warranties or representation whether expressed or implied, including any implied warranty of merchantability or fitness. In no event shall MSD or its suppliers be liable for special or consequential damages.

*Intended normal use means that this item is being used as was originally intended and for the original application as sold by MSD. Any modifications to this item or if it is used on an application other than what MSD markets the product, the warranty will be void. It is the sole responsibility of the customer to determine that this item will work for the application they are intending. MSD will accept no liability for custom applications.